

JUMPSTARTING

1. Turn ignition OFF. Turn off all accessories such as lights, radio, air conditioner, etc...
2. Make sure all switches on the Jumpstart System are turned OFF.
3. Securely connect the Red (+) clamp to your vehicle battery's positive (+) battery terminal.
4. Check that vehicle is negatively grounded (most vehicles). Securely connect the negative (-) black clamp to the vehicle chassis, engine block or a non- moving metal part of the vehicle which is verified to be grounded. Do not clamp directly to negative battery terminal, carburetor, fuel lines, or sheet metal body parts. Check cable connection polarity indicator.
5. Start vehicle. If vehicle does not start, wait 3 minutes before trying again (failure to wait may damage Jumpstart).
6. After vehicle starts, disconnect the black negative clamp first than the red positive clamp.

SPECIFICATIONS

- | | |
|----------------------|---|
| 1. Built-in Battery: | 12-Volt Rechargeable Sealed Lead Acid Battery |
| 2. Work Light: | 5 x LEDs |
| 3. Compressor: | 260 PSI Reading Gauge |
| 4. Inverter: | 230 volt AC 200 Watt (400 Watt Peak) |
| 5. 12V Power Port: | 12-volt 11A max. |
| 6. Charging Time: | 38 hours by AC charger at home
16 hours by DC charger in vehicle |

The WEEE symbol  on this product means that this product should be ethically dismantled or recycled to minimise environmental impact. Please check with your local authority for more information.

IMPORTANT: ADDITIONAL SAFETY INFORMATION

This Power Station/Emergency Jumpstart is **NOT** intended for use by persons (including children) with reduced physical, sensory or mental capabilities, or lack of experience and knowledge, unless they are supervised or have been given instruction concerning use of the Power Station/Emergency Jumpstart by a person responsible for their safety.

EC DECLARATION OF CONFORMITY**In accordance with EN ISO 170504:2004**

We; The Ace Supply Co Ltd., T/A Streetwize Accessories

Of; Unit 9, Warth Rd Ind Estate, Warth Road, Bury, Lancashire BL9 9NB

And in accordance with the following Directive(s):

- | | |
|-------------|---|
| 2004/108/EC | The Electromagnetic Compatibility Directive |
| 2011/55/EC | The Low Voltage Directive |
| 2006/42/EC | The Machinery Directive |

hereby declare that: **SWPP5 - 5 in 1 Power Station with Air Compressor**

is in conformity with the applicable requirements of the following directives:

EN55014-1:2006, EN55014-2:1997+A1:2001, EN55015:2006+A1:2007, EN61541:1995+A1:2000, EN61000-3-2:2006, EN61000-3-3:2008, EN61558-1:1997+A1:1998+A11:2003, EN61558-2-4:1997, EN61558-2-17:1997, EN60950-1:2006, EN60335-1:2002+A1:2004+A2:2006+A11:2004+A12:2006
2011/65/EU Verification Testing Of Restriction Of hazardous Substances (ROHS)

Signed by: Name: *Antony Collier* Antony Collier - QC Manager

Signed at Bury on 18/12/12



Lancashire
BL9 9NB

Streetwize Accessories E-mail: sales@streetwizeaccessories.com www.streetwizeaccessories.com

Professional Solutions

5-in-1 Power Station & Emergency Jumpstarter with Air Compressor

- 900 Amp Battery Jumper
- 12 Volt Power Station
- 260 Psi Air Compressor
- Work Light
- 200 Watt Power Inverter

WELCOME: This product has been carefully engineered and manufactured to give you dependable operation. Please read this manual thoroughly before operating your new product as it contains the information you need to become familiar with its features and obtain the performance that will bring you continued enjoyment for many years. Please keep this manual on file for future reference.

IMPORTANT: PRIOR TO USE, READ AND UNDERSTAND ALL WARNINGS, CAUTIONS AND INSTRUCTIONS INCLUDED IN THIS INSTRUCTION MANUAL, AND THOSE PUBLISHED BY YOUR VEHICLE BATTERY MANUFACTURER AND MANUFACTURER OF ANY DEVICE INTENDED TO BE USED WITH THIS UNIT. RETAIN THESE INSTRUCTIONS FOR FUTURE REFERENCE.

LOCATION OF CONTROLS

1. Rubberized Handle
2. Air Compressor On/Off Switch
3. Air Compressor Gauge
4. Heavy Duty Booster Clamps
5. 12V Socket
6. LED Work Light On/Off Switch
7. Voltmeter
8. Battery Status Button
9. 5 LED Work Light
10. Inverter On/Off Switch
11. AC Outlet
12. Air Hose Compartment
13. Jumpstarter On/Off Switch
14. Air Cooling Fan

CAUTIONS

- To protect against electrical hazards, do not immerse charger, adapters, or unit in water or other liquid.
- Close supervision is necessary when used near children.
- Do not use unit for applications other than its intended use.
- Recharge battery after every use.
- Avoid touching eyes when working with batteries.
- If battery acid comes in contact with skin or eyes, flush with water immediately and get medical attention.
- Remove metal jewelry or objects from your body when using the unit.
- Never allow red and black clamps to touch each other or to touch the same metal object.
- Always connect the red (+) clamp to the positive battery terminal first.
- Do not connect black (-) clamp to the negative battery terminal, connect it to a non-moving metal part on your vehicle.
- Jumpstart vehicles in a well ventilated area only.
- Monitor the pressure gauge during use. Be careful not to over-inflate objects.

WORK LIGHT:

- Simply turn the work light switch (on front panel) to ON position
- The 5 x LEDs will illuminate.
- Turn OFF while not in use.

IMPORTANT WARNING: This product is only supplied with a minimal amount of charge at manufacture, therefore for this product to operate correctly it has to be fully charged for a period of 38 hours **IMMEDIATELY** after purchase, this is essential **BEFORE ANY USE!** & cannot be used **DURING** the charge period. Failure to adhere to these conditions may invalidate the products warranty.

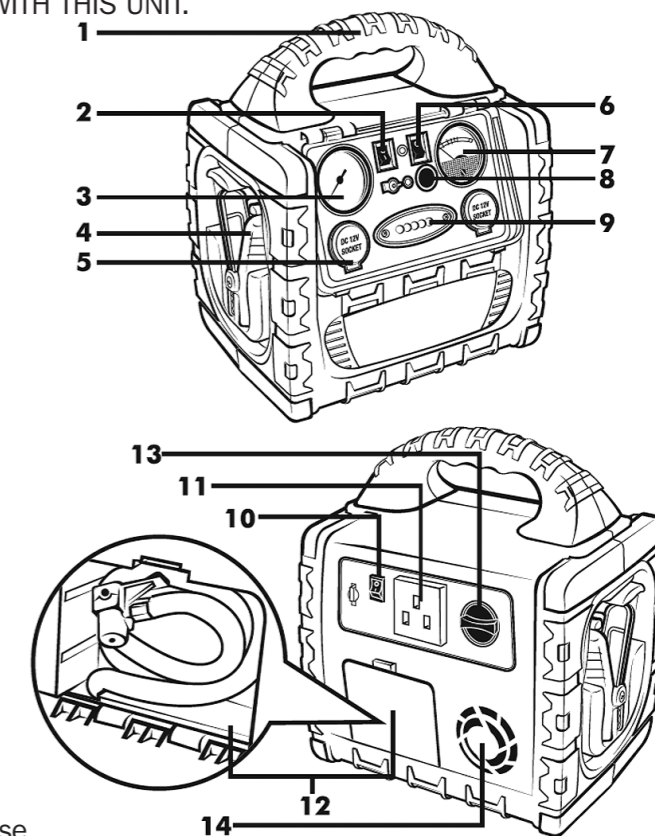



BATTERY STATUS:

- Press and hold the Battery Level Button.
- The Voltage Meter will show the battery level.
- 13~15 Volt: Ready to use.
- 12 Volt: Charge necessary
- Below 12 Volt: Charge immediately

CHARGING YOUR JUMPSTART SYSTEM

AC Charging At Home (230v)

1. Completely charge your Jumpstart before using for the first time.
2. Before recharging from an AC outlet, be sure the source is right. (i.e.110 volts or 230 volts)
3. Use only the chargers provided with unit.
4. Keep the power on/off safety switch in OFF position while charging.
5. Plug the AC charging cord into any standard wall outlet and the other end into the AC/DC charging input socket.
6. Full charge takes approximately 34 hours - Do not exceed recommended charging time 48 hours

DC Charging In Your Vehicle (12v)

1. Keep the power on/off safety switch in OFF position while charging.
2. Plug the DC charging cord into any 12 volt (cigarette lighter) outlet and the other end into the AC/DC charging input socket.
3. Full charge takes approximately 12 hours

Do not exceed recommended charging time – initial charge 24 hours.

USING AIR COMPRESSOR

1. Open compartment door at the back of the power center and pull out air hose. Make sure nozzle lever is in the UP position.
2. Attach the valve adapter to the valve stem of tires and push the valve adapter lever down to lock into place.
3. Turn compressor switch on front panel to ON position.
4. Monitor the pressure gauge while inflating.
5. When appropriate pressure has been reached, turn compressor OFF and disconnect hose.

Note: It is recommended to use a separate air gauge to check the actual inflation pressure. When desired pressure is reached, turn off compressor, turn the locking thumb lever to up position and remove stem connector from valve stem. Also remove valve stem adapter if applicable.

USING 12 VOLT DC POWER PORT

1. Remove the protective cover.
2. Plug in your 12 volt accessory.
3. Turn power port switch to ON.
4. At full charge the power center will power B/W TV, spotlight for 4 hours, mini-cooler for 3 hours, portable vacuum, coffee maker for 1 hour.

Time may vary depending upon current draw of attached accessory.

USING AC INVERTER

1. Prior to connecting inverter, maker sure the inverter switch in OFF position.
2. Prior to plugging in device, make sure the device is OFF and ensure the current drawn of this device is max. 200 watt.
3. Connect the device electrical plug into the inverter receptacle.
4. Press the inverter to ON position. If the inverter is working properly, a green LED indicator will illuminate. Now turn ON the device. If the green indicator remains on, then the system is operating properly. If the inverter green LED light turns OFF, turn off the device then turn off the inverter immediately. See the trouble shooting guide. The inverter may have been over loaded or the input voltage may be too low.

CAUTION:

Some rechargeable devices are equipped with a separate charger, which can be connected into this inverter AC receptacle. However certain rechargeable devices are manufactured with built-in chargers (see device owner’s manual). This category of devices may cause internal damage to inverters and should not be used with this inverter. The temperature of the device must be monitored for the first 15 minutes of operation. Abnormally elevated temperature of the device is an indication that they should not be used with this inverter.

STORAGE:

This unit may be stored in any position. Make sure the clamps are secure inside the booster cable storage covers. Store at room temperature. If not used for a prolonged period of time, recharge every 2 months in the winter and every month in the summer.

Trouble	Cause	Remedy
Lack of power output	1. Power center voltage below 12 volt. 2. Excessive current drawn by appliance being operated. 3. Inverter not completely warmed up. 4. Inverter fuse blown.	1. Recharge the Power Center immediately. 2. Reduce load to maximum 200 watts. 3. Turn OFF the device and inverter. Disconnect device. Turn the inverter ON and leave running for a minimum of 2 minutes. Turn OFF inverter, quickly plug in device to inverter making sure device is OFF prior to connection. Turn ON the inverter and the device. 4. Replace a new 25 AMP rated fuse. To replace fuse: REMOVE fuse with a needle nose pliers and replace with a new 25 AMP fuse.
LED light OFF	1. Inadequate power or excessive voltage drop. 2. Inverter is overloaded.	1. Check power center and recharge is voltage drops below 12 volt. 2. Replace load to maximum of 200 watts.
Television/Power Tool will not start	1. High surge wattage requirement to start-up.	1. Toggle the On/Off switch in quick succession a total of 5 times in order to generate the necessary power to start the device. If the device does not turn on or start up in 5 cycles of ON/OFF trials. This inverter will not work with the device.
Television Interference	1. Picture breaking up (snow).	1. Place the inverter (power center) as far as possible from TV, the antenna and the coaxial cable. 2. TV station may be out or range.
Static/Noise interference in audio system	1. Sound system has weak alternating current shielding.	1. Do not use inverter with low quality audio AC filtering system. 2. Replace audio system with high quality noise filtering.